

Cannabis Licensed Producer Operations Manual

Version 6.0 | June 2024

Table Of Contents

1. Introduction	2
1.1 Introductory Note	2
1.2 Glossary of Terms	3
1.3 Cannabis in Alberta 101	5
2. Selling to AGLC	5
2.1 General Information	5
2.2 Marketing Products in Alberta	5
2.3 Standard Supply Contract Considerations	7
3. PRODUCT REGISTRATION	8
3.1 Product Registration Introduction	8
3.2 Product Description Guidelines	8
3.3 Product Description Guidelines	9
3.4 Quality Assurance Requirements	10
3.5 Product IMAGE Requirements	12
4. PACKAGING, LABELLING & SHIPPING	13
4.1 Packing, Labelling & Shipping Introduction	13
4.2 Labelling Requirements	13
4.3 Packing Products for Shipment to AGLC	19
4.4 Shipping to AGLC warehouse	20
4.5 Non-Compliance Penalties	23
4.6 Value-Add Services	24
4.7 Health Canada Consumer Information sheet	24
5. PRODUCT RETURNS & RECALLS	25
5.1 Product Returns	25
5.2 Product Recalls	25
6. Payments	26
6.1 Payment Set-up	26
6.2 Invoicing AGLC	26
6.3 Credit Adjustments for Penalties or Fees	28
6.4 Taxes	28
6.5 Payment Related Inquiries	28
7. Contacts	29

1. Introduction

Welcome To The Alberta Cannabis Industry

1.1 Introductory Note

This Operations Manual details the appropriate procedures for interacting with Alberta Gaming, Liquor & Cannabis (AGLC) as a wholesale, recreational cannabis reseller. AGLC is the sole wholesaler of cannabis products in Alberta, mandated to responsibly supply Alberta's cannabis market in alignment with provincial law.

AGLC is committed to:

- Keeping cannabis out of the hands of children and youth
- Protecting public health
- Promoting safety on roads, in workplaces and public spaces
- Limiting the illegal cannabis market
- Continuing to offer choices Albertans can trust

This Operations Manual should be used as a reference for understanding how to work with AGLC to supply cannabis products to Alberta's cannabis market.

Following all the procedures outlined in this document **does not** constitute adherence to the complete set of AGLC policies. All cannabis producers licensed by the federal government and operating in Alberta must adhere to federal, provincial, and municipal law, policies established by AGLC and the terms of any supply contracts with AGLC. Additional policies that apply to federally licensed cannabis producers and their representatives are in the **Cannabis Representative Handbook**.



Check [aglc.ca](https://www.aglc.ca) often for updates to this document.

This document evolves and changes as the cannabis industry in Alberta grows and matures. Be sure to check [aglc.ca](https://www.aglc.ca) often to ensure that you are using the latest version.

Details regarding Alberta's approach to cannabis legalization can be found at [alberta.ca/cannabis](https://www.alberta.ca/cannabis). For more information regarding the legalization and regulation of cannabis in Canada, please visit [canada.ca/cannabis](https://www.canada.ca/cannabis).

1.2 Glossary of Terms

- **Alberta Cannabis Call Centre** – The Alberta Cannabis Call Centre is AGLC’s main communications channel for working with retailers as well as addressing questions and comments from Albertans.
- **Advance Shipping Notice (ASN)** – A notice that a Licensed Producer must send to AGLC’s warehouse to notify of the contents of an inbound shipment. The ASN must be submitted via the **ASN Portal**.
- **AGLC** – Alberta Gaming, Liquor & Cannabis
- **Appointment Request Form (ARF)** – A document to request an appointment time for delivering goods to AGLC’s warehouse.
- **BCMB** – Beverage Container Management Board. The BCMB is responsible for regulating Alberta’s beverage container recycling system and leads the development of policy and programs that enable the recycling of beverage containers in Alberta.
- **Bill of Lading (BOL)** – A hauler or carrier’s contract, which may also act as the receipt of goods transported and delivered to the consignee.
- **Cannabis** – Any part of a cannabis plant, including the phytocannabinoids produced by or found in such a plant, regardless of whether that part has been processed or not.
- **Cannabis accessories** – Accessories that promote the responsible and legal consumption and storage of cannabis.
- **Cannabis licence** – A licence under the Gaming, Liquor and Cannabis Act that authorizes the purchase, sale, transport, possession, and storage of cannabis.
- **Cannabis product** – A product that contains cannabis.
- **Cannabis representative** – A corporation or individual registered with AGLC who is in the business of representing a cannabis supplier in the sale of the cannabis supplier’s cannabis products.
- **Cannabis supplier** – A person who holds a federal licence that authorizes the person to produce cannabis and cannabis products for commercial purposes or to sell cannabis to AGLC.
- **CBD**– Cannabidiol
- **Certificate of Analysis (CoA)** – Certificate of Analysis is a document issued by the LP that confirms that a regulated product meets its product specification and presents actual numerical results and refers to the lot number, raw material specifications and validated test methods used as per Cannabis Regulations.
- **Common Carrier** – a business that provides merchandise transportation services in compliance with all applicable laws and regulations governing commercial transportation in Alberta.
- **Connect Logistics Services (CLS)** – The warehouse designated by AGLC to receive inventory and ship on behalf of AGLC.
- **Electronic Funds Transfer (EFT)** – The electronic transfer of money from one bank account to another via computer-based systems.
- **GLCA** – The Gaming, Liquor and Cannabis Act.
- **GLCR** – The Gaming, Liquor and Cannabis Regulation.
- **Hazard Analysis & Critical Control Points (HACCP)** – A management system in which cannabis product safety is addressed by analyzing and controlling biological, chemical, and physical hazards from raw material production, procurement, and handling to manufacturing, distribution and consumption of the finished product.
- **Inspector** – An Inspector of AGLC, a police officer as defined in the Police Act or someone designated by AGLC as an Inspector under the GLCA.

- **Licensed premises** – All areas associated with the operations of the licence, including, but not limited to:
 - Areas cannabis products may be sold; and
 - Any storage room, lobby, hallway, or other service areas used by the licensee in support of the areas where cannabis products may be sold.
- **Licensed producer (LP)** – A business licensed by the Government of Canada to produce cannabis products. Within the context of this document, the term refers specifically to those authorized to produce recreational cannabis products.
- **Licensee** – The individual, partnership or corporation holding a retail cannabis store licence.
- **Minor** – A person under the age of 18 years.
- **Mixed SKU or lot notification** – A piece of paper is attached to any pallets being delivered to AGLC to notify the receiving crew that the pallet has multiple SKUs or lots. The notification should be oriented toward the delivery truck’s cargo door. Print this form on bright yellow paper.
- **Online retail** – Products sold by licensed retailers through an internet-based store directly to consumers.
- **Packing slip** – Included with each pallet, this document contains a listing of each Master Case on the pallet and each SKU associated with the packed products.
- **Preventive Control Plan (PCP)** – a written document that demonstrates how hazards to cannabis products are identified and prevented, eliminated, or reduced to an acceptable level.
- **QA** – Quality Assurance
- **QAP** – Quality Assurance Persons
- **Qualified Cannabis Worker (QCW)** – Any person who is 18 years or older, has successfully completed the SellSafe Cannabis Staff Training program, has passed a criminal record, check and has been deemed qualified by AGLC.
- **SellSafe Cannabis Staff Training** – A mandatory social responsibility training program designed to help retail cannabis staff understand their responsibilities to their customers. The program also helps workers understand Alberta’s cannabis laws and AGLC’s policies to follow them.
- **Stock Keeping Unit (SKU)** – A common term for a unique numeric identifier, typically in a database. A specifically assigned product number for each variation of an item. The SKU number represents variations of the item by size, colour, type, or any other specific designation to aid in computer ordering and inventory control.
- **Staff** – Any QCW employed by the Cannabis Representative or contracted by the Cannabis Representative or a third party working in the cannabis industry to perform assigned or delegated duties.
- **SOP** – Standard Operating Procedure
- **Supply Contract** – A standard contract between an LP and AGLC to supply the Alberta market with cannabis products through AGLC.
- **THC** – Delta-9 Tetrahydrocannabinol

1.3 Cannabis in Alberta 101

1.3.1 The Role of AGLC

The GLCA empowers Alberta Gaming, Liquor & Cannabis to regulate and supply retail cannabis products to Albertans. To this end, AGLC has two roles within the Alberta cannabis market:

- **Regulator** – AGLC regulates the cannabis industry in Alberta and acts as a neutral party in ensuring that both private retailers and their online retail offering operate safely, responsibly and in accordance with the law and AGLC policies.
- **Wholesaler** – AGLC is the only source of recreational cannabis products for private retailers in Alberta. AGLC purchases cannabis products from select federally licensed LPs around the country. This model of operation has been adopted by AGLC to ensure a steady supply of cannabis products to Albertans at a more stable price point as the cannabis market matures.

Since LPs are licensed and regulated by the federal government, AGLC requires all LPs it does business with to be in good standing with the federal government. AGLC actively checks LPs' licences on the federal government website. AGLC regulates LPs as Registered Supplier Representatives and may engage with LPs for the purpose of regulatory investigations and enforcement of AGLC policy. LPs should refer to the **Cannabis Representative Handbook** for information on how AGLC policy applies to them and the **Gaming, Liquor and Cannabis Regulation** and the **Gaming, Liquor and Cannabis Act** to ensure they are abiding by provincial law.

2. Selling to AGLC

How To Supply Cannabis Products To The Alberta Market

2.1 General Information

AGLC purchases cannabis directly from LPs to supply the Alberta market. AGLC is the sole purchaser of recreational cannabis products in Alberta from LPs across Canada and does so at its discretion.

AGLC purchases products based on market demand like any private retailer or private wholesaler. AGLC seeks to purchase products that best fulfill a niche in the market from reputable sellers with sustainable operations.

Products AGLC purchases from LPs will be made available for sale as wholesale products for Alberta's private retailers.

AGLC engages with LPs through supply contracts rather than redetermining the suppliers for every order. This approach is taken to secure a steady supply of high-quality, recreational cannabis products for the Alberta market.

2.2 Marketing Products in Alberta

2.2.1 AGLC As A Buyer

AGLC purchases cannabis products at its discretion and is not obligated to carry any product or product category. AGLC purchases products it believes will satisfy the Alberta market from vendors it trusts and will be responsible, reliable partners.

2.2.2 Cannabis Representatives

A cannabis representative is a company that markets cannabis products in Alberta. A federally licensed cannabis supplier must register its own company as a cannabis representative. Once registered, a federally licensed supplier may hire a registered cannabis representative to market cannabis products on its behalf. A federally licensed supplier may also work with brand partners to supply branded products in Alberta; however, that brand partner must also be a registered cannabis representative.



Details available in the Cannabis Representative Handbook.

Additional details regarding the role of Cannabis Representatives and the laws and policies that apply to them may be found in the **Cannabis Representative Handbook** available on aglc.ca.

2.2.3 Press Release Approvals

AGLC must approve all press releases from its LP vendors related to dealings with AGLC or its business operations. All relevant press releases must be sent to CannabisMerch@aglc.ca for approval by AGLC's Corporate Communications team and Vice President, Liquor and Cannabis. AGLC will try to review and respond to press release review requests within five business days, but reviews for controversial, lengthy, or complicated materials may take longer.

2.2.4 Complying With Regulation

When marketing products to the Alberta market, ensure that all efforts comply with federal and provincial legislation, including the following:

- The LP, the LPs employees, subcontractors and agents and its Cannabis Representative are prohibited from directly or indirectly offering or providing anything of value to licensed cannabis retailers in Alberta.
- All cannabis representative managers, supervisors, and employees involved in marketing cannabis products must be QCWs.
- Reasonable steps must be taken to ensure that a person under 18 years old does not view any advertisement.

Additional information regarding the policy and legislation that cannabis representatives must follow to operate in Alberta can be found in the **Cannabis Representative Handbook**, the **Gaming, Liquor and Cannabis Regulation** and the **Gaming, Liquor and Cannabis Act**.

2.3 Standard Supply Contract Considerations

AGLC requires a supply contract to buy cannabis products from a federally licensed producer. This supply contract guarantees service levels and is used for AGLC to ensure a steady supply of high-quality cannabis products to the Alberta market and the best possible value for Albertans. Supply contracts between AGLC and LPs typically contain the following key terms:

- **Order fulfillment timing (PO Close Date)** – LPs must fulfill purchase orders from AGLC within 30 business days of receiving an order unless otherwise specified. Non-compliance with this term may induce a financial penalty.
- **Inbound cost recovery** – The LP must pay all costs related to the completion of inbound delivery, acceptance and quality assurance of any products delivered to AGLC.
- **BCMB** – The LP is required to register all beverage containers with the Beverage Container Management Board (BCMB) for cannabis beverage products sold in the province of Alberta. LPs are required to register their non-refillable beverage containers in the **Beverage Container Registration Portal** to obtain their registration codes. LPs will be charged a nominal fee from BCMB for each SKU registered. Beverage listings at AGLC will not be activated until the registration is completed and verified.
- **Expiry limitation** – Products delivered to AGLC must have at least three-quarters of the remaining shelf life upon receiving. Products that arrive with less than three-quarters of the remaining shelf life may be returned or not accepted. Shelf life is defined as the amount of time, in days, that the product remains fit for consumption, measured from when the cannabis product was packaged.
- **Lowest price guarantee** – AGLC is entitled to the lowest price offered for a product (excluding taxes). If a lower price is offered to a third party, the LP must lower the price offered to AGLC to match that price. This guarantee also applies to temporary promotional pricing. AGLC is entitled to any promotional price for the duration of the promotion. AGLC, at its discretion, may invoice the LP for the difference between the purchase price and the promotional price for all goods remaining in the AGLC supply chain and request payment or deduct from the next payment. All open purchase orders will also be reissued to the new price.
- **Additional fees** – LPs will be charged the following fees, which will be deducted from AGLC's payment to the LP:
 - Listing Fee: \$250 per SKU; and
 - Salvage/Damage: two per cent (2%) of gross shipment amount.
- **Shipping compliance** – Any non-compliance with the packaging, labelling, and shipping criteria outlined in the contract will result in a penalty up to \$1,000 per occurrence and increase up to and including the cost to remedy the error. It may also result in the rejection of the shipment. AGLC may not accept early or late shipments. Short or delayed shipments are subject to a penalty of up to five per cent (5%) of the cost of the short or delayed portion of the order.
- **Payment** – Upon receiving an accurate invoice referencing the purchase order number, AGLC will pay the LP the purchase price in effect on the date the goods were ordered within 60 days after the invoice date. If payment is made within 15 days after the invoice date, AGLC will receive a two per cent (2%) discount on the order. The invoice cannot be dated before AGLC has accepted the goods.

- **Returns to the LP** – Products sold to AGLC may be returned to the LP for any reason, including if the products remain unsold, are deemed unsatisfactory or have a diminished remaining shelf life that negatively impacts resale value. All returns conducted with an LP will be at the expense of the LP. AGLC, at its discretion, may choose to invoice the LP for goods returned and request payment or deduct from the next payment. A common carrier must be used for pickup.
- **Recalls** – Under the supply contract terms, both AGLC and the LP are obligated to promptly comply with any product recalls issued by the LP or any applicable governmental authority. LPs must notify AGLC immediately if a recall is declared.
- **Audits** – AGLC may conduct an audit of the LPs financial records and production facilities to ensure compliance with the contract, alongside all operations that fall under the cannabis regulations as part of product approval, renewal or investigation of issues encountered with products at AGLC. For audits of financial records, AGLC will provide the LP with 5 days advance written notice.
- **Ethical standards** – Upon request by AGLC, the LP will deliver copies of all written ethical standards, conflict of interest policies and codes of conduct established or observed by the LP in its business practices or about its employees, subcontractors, or agents. AGLC may choose not to re-sign contracts based on breaches of ethical conduct codes.



Observe the terms of the original contract

The term items highlighted in the list above are illustrative only and do not encompass the full set of terms that will be in a supply contract between and LP and AGLC. LPs should refer to their individual supply contract to understand their obligations.

3. PRODUCT REGISTRATION

Providing AGLC With Product Information

3.1 Product Registration Introduction

Following contract initiation, it will be the responsibility of the LP to provide product information, including digital photographs of products (optional), to AGLC for registration. The \$250 listing fee covers expenses associated with validating product information and creating a product page so retailers may purchase the product.

The contract between an LP and AGLC will stipulate terms and conditions, any additional fees, and other considerations. This manual should be used as a reference only. The terms of the individual contract that AGLC has with each LP take precedence over this document.

3.2 Providing Product Registration Information

To register a product, LPs must complete the Product Master Template to provide extensive details about product attributes. The template will be emailed to the LP after signing the contract. LPs must provide a digital copy of product labels to AGLC QA for review and approval. The information required may be subject to change at the AGLC's discretion. Any changes made to an already approved and registered product's attributes, including but not limited to labelling, packaging, branding or best before dates, will require re-approval by AGLC QA before implementation.

3.3 Product Description Guidelines

3.3.1 Description Introduction

As an LP, you want to put your best foot forward when presenting your cannabis products to Albertans. It works best if you develop unique, informative descriptions for your products.

AGLC uses simple and direct language wherever possible while keeping the tone conversational and engaging. AGLC wants to educate retailers without sounding like a scientific journal, using language everyone can understand for inexperienced and seasoned consumers. Descriptions can be a maximum length of 1,000 characters including spaces and must not contain any special characters.

A few examples are shown here; for more details, refer to the Ecommerce Manual, available by contacting CannabisCreative@aglc.ca or your Category Management Specialist. AGLC reserves the right to edit any information before it is published online.



Do not state 'feelings' or make medical claims in your product descriptions.

AGLC and Health Canada only allow for the statement of recreational, grounded and factual descriptions of the products sold in Alberta. LPs must not make claims like the following:

"Studies have shown this product to cure glaucoma." "It will feel like you are on a cloud."

"This product produces a vivid and heady high."

Do not use product descriptions that could appeal to children.

3.2.2 Description Best Practices

DO	DON'T	REASONING
Describe unique, non-medical product attributes, like appearance, scent and flavour, history, genetics, or growing conditions.	State the obvious or make medical claims.	Call out what makes your product stand out without making unproven claims.
Use full sentences	Write a novel	Conversational language draws in consumers but dragging things out can push them away.
Keep it simple	Make it too short	Get to the point quickly, but don't leave out essential information consumers need to make a decision.
Describe the product	Describe the product effects	AGLC does not supply medical products and avoids describing product effects.

3.4 Quality Assurance Requirements

AGLC has quality assurance (QA) requirements that must be met by LPs prior to AGLC's purchase of new cannabis products. This document serves to outline all the QA requirements that must be submitted to AGLC QA (CannabisQualityAssurance-DL@aglc.ca) prior to a PO being issued for new product categories and new SKUs being offered to AGLC. Upon receiving a product call confirmation email from AGLC Category Management Team, LP must submit the applicable QA documents to ensure timely product approval.

For a brand-new LP offering products for the first time to AGLC, or for an existing LP offering a product in a new category please refer to requirements found in sections 3.4.1, 3.4.2, 3.4.3 and 3.4.4.

For an existing LP providing a new SKU in a previously approved category, please refer to requirements found in section 3.4.2.

In case of revisions to any products after submission, please send all relevant supporting documents to CannabisQualityAssurance-DL@aglc.ca and the respective Category Management Specialist, as soon as possible. Please note that review will be completed based on the information provided as a part of AGLC internal requirements, however, the LP is responsible for ensuring full product compliance against the Cannabis Act and Cannabis Regulations.

3.4.1 AGLC QA Requirements – Approval of New LP and/or New Product Category

Please provide a copy of the following to CannabisQualityAssurance-DL@aglc.ca for the approval of new cannabis product categories being sold to AGLC.

1. Sample of Certificate of Analysis Template (CoA)
2. Recall Standard Operating Procedure (SOP) & LPs Recall Contacts
3. Customer Complaint Management SOP

Additional Information:

- If offering a new product in a category that an LP has previously been approved for, please refer to **section 3.4.2 only**. “AGLC QA Requirements – Approval of New SKU (Mandatory)”. Please note that **section 3.4.2 is mandatory** for **ALL** new SKU submissions.
- If offering extracts for sale for the first time to AGLC, please refer to **section 3.4.3** “Additional AGLC QA Requirements – Approval of New Category - Extracts” for additional requirements.
- If offering edibles for sale for the first time to AGLC, please refer to **section 3.4.4** “Additional AGLC QA Requirements – Approval of New Category - Edibles” for additional requirements.

3.4.2 AGLC QA Requirements – Approval of New SKU (Mandatory)

Please provide a copy of the following requirements to CannabisQualityAssurance-DL@aglc.ca for the approval of a new SKU in a **previously approved** category. These requirements only apply when an LP has been previously approved for sale of a specific product category by AGLC QA:

1. PDF/Picture of Unit Label for Each Individual SKU (Including ALL Health Canada required labelling details)
2. PDF/Picture of Unit Packaging for Each Packaging Type
3. PDF/Picture of Case Label (applicable to new suppliers only)
4. Child Resistant Certification for Each Packaging Type
5. Any changes that have been made to previously submitted documentation (i.e., LP recall contacts, PCP/HACCP changes)
6. Shelf-Life Study (if available)

3.4.3 Additional AGLC QA Requirements – Approval of New Category – Extracts (i.e. concentrates, infused pre-rolls, vapes etc.)

Please provide a copy of the following additional requirements to **CannabisQualityAssurance-DL@aglc.ca** for the approval of vape/extract products being sold to AGLC. These requirements serve as a supplement to “AGLC QA Requirements for Approval of New SKU (Mandatory)”.

1. Identification and Analysis of Hazards - Prevention, Elimination and Reduction of Hazards (PCP or HACCP plan)
2. Declaration of Allergens and Allergen Management Program (if applicable)

Applicable to Products Containing a Pre-Installed Battery (i.e. vape pen)

3. UL8139 Certificate or Equivalent for Vapes
4. CSA-E62133 Certificate or Equivalent for Lithium Batteries
5. Safety Data Sheet (SDS)

Declaration of Leachability and Hazardous Materials (for vape only)

6. Does your product contain leachable materials [Bisphenol A (BPA), phthalates and styrene from plastic polymers? - If yes, please provide documentation to demonstrate that materials are within tolerance.
7. Does your product contain added ingredients such as Triacetin, Phytol, Polyethylene Glycol (PEG 400), Propylene Glycol (PG), Medium Chain Triglycerides (MCT), Vegetable Glycerin (VG)? If yes, please provide documentation to demonstrate that above constituents are within safe limits for inhalation.
8. Does your product use a heating element made of Nickel Chromium Alloy? If yes, please provide documentation to demonstrate that above constituents are safe for human use. If no, please declare heating element properties.

3.4.4 Additional AGLC QA Requirements – Approval of New Category – Edibles (i.e. beverages, chocolates, soft chews, etc.)

As new products or product categories come online, a Supplier Assessment Questionnaire with detailed questions is sent to LPs and must be completed.

Please reach out to **CannabisQualityAssurance-DL@aglc.ca** for a copy of this questionnaire.

This questionnaire specifies:

1. Supplier details, including:
 - supplier name and address
 - supplier telephone and fax numbers and email address
 - manufacturing site address (if different from supplier address)
 - QAP name, telephone number and email address
2. Product details, including:
 - site location
 - product name
 - SKU number
 - product type
3. Accreditation details, including:
 - date of last Health Canada audit
 - accreditation received/audit result
 - third-party accreditation/audit details (if any)
 - accreditation received/audit result

4. **Quality Assurance Questionnaire** covers food safety, sanitation procedures, manufacturing processes, worker hygiene and illness practices, pest control, cross-contamination risks, recall and customer complaint processes, allergens and allergen control, inspections, calibration, and internal audits. Detailed questions are outlined in the Supplier Assessment Questionnaire.
5. Supporting documentation, including:
 - PCP, HACCP or Food Safety Plan (List of hazards with controls)
 - Sample of Certificate of Analysis
 - Recall Plan (with recall contact information)
 - Allergen Management Program
 - Customer Complaints Program
 - Glass and Brittle Plastic Policy
 - Electronic copy of product label
 - Physical sample and/or electronic copy of packaging with child resistant certificate
6. **Allergen Checklist**, determining the presence of common allergens in the product, in other products manufactured on the same line and/or present in the same manufacturing facility.
7. Declaration, including:
 - signature
 - printed name
 - position
 - date

3.5 Product IMAGE Requirements

Product photos are not a requirement; however, they help present your cannabis products to retailers. There are several e-commerce standards you must follow to provide appropriate product images. In addition, several specifications ensure all product images meet system requirements and are compatible with AGLC's Business to Business (B2B) website.

These include general, consistent specifications for all images supplied, such as:

- width and height dimensions, in pixels
- image resolution, in dpi
- clearance and white space included in each image
- file format
- file naming convention
- removal of specific Total THC and Total CBD amounts and units of measure when/if visible in images
- upload and contact method

There are also specific product image requirements for each product subcategory, for example, canned beverages versus pre-rolls, versus chocolate bars, etc.

For detailed image requirements, refer to the Ecommerce Manual, available by contacting CannabisCreative@aglc.ca or your Category Management Specialist.

All images are subject to review and approval by AGLC.

AGLC reserves the right to use these images without permission for purposes outside of the B2B website.

4. PACKAGING, LABELLING & SHIPPING

Preparing And Sending Your Product To The AGLC Warehouse

4.1 Packing, Labelling & Shipping Introduction

This section of the document provides LPs with the information necessary to prepare the delivery of goods to AGLC.

For AGLC to accept goods from an LP, the packaging, labelling, and shipping guidelines in this manual must be adhered to. AGLC may choose to cease purchasing from an LP, refuse a shipment or impose a penalty if an LP does not comply.

Barcodes must be sent to Cannabisbarcodes@connect-logistics.com for approval before the first purchase order can be created. Electronic copies of unit labels and child resistant packaging certification must be sent to CannabisQualityAssurance-DL@aglc.ca before the first purchase order can be created. Any questions related to these guidelines should be directed to the Category Management Specialist or CannabisQualityAssurance-DL@aglc.ca.



Ensure all regulations are followed.

This document only outlines AGLC's labelling, packaging, and shipping requirements. LPs must comply with all laws stipulated by the federal government, including the **Consumer Packaging and Labelling Act** and the **Cannabis Act**.

4.2 Labelling Requirements

4.2.1 Certificate of Analysis of Goods

A Certificate of Analysis of Goods (CoA) is required for each lot. This certificate demonstrates the products being delivered conform to federal standards.

Each CoA submitted to AGLC must have product identifiers such as:

- Product name, as per the listing description submitted on the Cannabis Product Master
- Finished product lot number
- CoA lot number is an exact match against the case label, unit label, and barcode scan.

Special characters in the lot number are not permitted as they may present issues in receiving the product that would need to be corrected.

Each CoA also needs to present all required Health Canada testing results that pertain to the class of cannabis being shipped. The CoA must declare the Total THC and Total CBD potency value.

The CoA must be uploaded to the ASN Portal at least **48 hours** before the product's arrival date. The potency analysis date must not be older than **twelve months** from the packaging date. LPs must retain the Certificates of Analysis and produce them upon request of AGLC.

AGLC may test the goods to ensure they meet the specifications set out in the Certificate of Analysis as provided by the LP. If the Certificate of Analysis varies from the test results, AGLC may return the goods to the LP.

4.2.2 Master Case Labelling Requirements

Each Master Case must have a human-readable label and a barcode that scans with standard equipment. Master Cases must be sealed with a security tape or tamper-evident seal to reduce shipping losses, tampering or product adulteration. The case label should not be used in place of security tape.

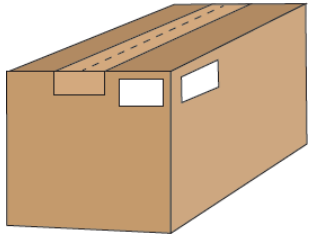

- Labels must be on two adjacent sides, and the barcode must be a minimum size of 9 cm (3.5”) by 2 cm (3/4”)
 - Human-readable labels must include the following categories printed in wording:
 - Licensed Producer Name
 - Case GTIN
 - Product Name
 - Product Category
 - Units per Master Case
 - Lot #
 - AGLC SKU # (CNB #)
 - Unit Size [net weight (g)]
 - Packaged-on Date
 - Only one lot number is permitted per complete Master Case. All units inside the Master Case must have the same packaged-on date. The packaged-on date on the units must match the Master Case label.
 - The human-readable label should have a font no smaller than size 10.
 - The barcode must conform to the GS1-128 format.
 - The barcode must lay flat and not wrap around the corners of the Master Case.

All multi-packs must have a unique master lot number incorporated to the unit case. The LP must be able to trace the multiple strains within the multi-pack back to the master lot number.

BARCODES

The barcode on each Master Case must follow the GS1-128 barcode format, as defined as:

MASTER CASE BARCODE FORMAT



MASTER CASE BARCODE SPECIFICATION

Application Identifier: 01

Description: Case GTIN

PCCMMMMIIIIID (e.g., “19501101530000”), as defined as:

- **P** = Package indicator; possible values include:
 - 1-8 = Differentiates standard each quantities of the same item within the Master Case
 - 0 or 9 = Not acceptable for AGLC cannabis products
- **CC** = UPC prefix
- **MMMMM** = Manufacturer code
- **IIIII** = Item identification number
- **D** = GTIN barcode check digit

Data Type: Numeric

Maximum Length: 14 digits (no variable length)

PACKAGED-ON DATE

Application Identifier: 13

Description: Packaged-On Date “190704”

Data Type: Numeric (in YYMMDD format)

Maximum Length: 6 digits (no variable length)

LOT NUMBER

For GS1 lot number information, our warehouse system will only accept up to 20 alphanumeric characters for this field. Lot number must be unique to each production lot and cannot be reused.

Application Identifier: 10

Description: Lot number “AB123”

Data Type: Any valid character (letters and/or numbers)

Maximum Length: Variable length permitted between 1 and 20 characters

Sample of Master Case label

2

1 **Licensed Producer**
XYZ Cannabis

2 **GTIN**
09501101530003

3 **Product Name**
Sensi Star 3.5g Dried Flower
or
Sensi Star 2 x 0.5g Pre-Rolls

4 **Product Category**
Dried Flower

5 **Unit Size**
3.5g

6 **Units per Case**
24

7 **Lot #**
AB-123

8 **SKU**
AGLC SKU #

9 **Packaged On Date**
July 4, 2019

10 
(01) 0 9501101 53000 3 (13) 190704 (10) AB-123
YYMMDD Lot Code Max 35 Digits
Print Barcode Here with Human Readable Below
Expanded GTIN Format Only

*** If you are entering a "Ship to", do not include the AGLC address. ***

Master Case labels must include the following human-readable wording:

1. Licensed Producer Name
2. Case GTIN
3. Product Name
4. Product Category
5. Unit Size [net weight 9(g)]
6. Units per Master Case
7. Lot #
8. AGLC SKU # (CNB#)
9. Packaged-on Date
10. Barcode

You don't have to register barcodes with GS1



Though AGLC stipulates that barcodes must be in the GS1 format, the barcodes do not need to be registered with GS1. AGLC follows GS1 guidelines for GTIN management.

4.2.3 Retail Unit Labelling Requirements

Each retail unit must have both a human-readable label and a barcode. AGLC accepts Expanded Databar or Databar Stacked for retail units.

The human-readable label must include:

- expiry date or statement that no expiry date has been determined
- packaged-on date
- lot number

The human-readable label should have a font no smaller than size 6.

- Barcodes on curved retail units, such as bottles of oil, must be printed to minimize curvature. For example, a barcode on a cylindrical oil bottle should be oriented vertically, so the barcode is as flat as possible. This guideline is to improve the readability of the barcode for electronic scanners. Barcodes on an extreme curvature will not reliably scan and will be deemed non-compliant. Barcodes must be a sufficient size to scan with standard equipment.



RETAIL UNIT BARCODE FORMAT

SAMPLE DATABAR EXPANDED



(01) 0 9501101 53000 3 (13) 190704 (10) AB-123

OR

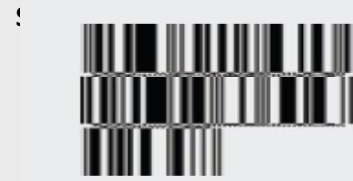

(01) 0 9501101 53000 3
(13) 190704
(10) AB-123

GTIN data stacks may have either 2, 3 or 4 stacks.

GTIN barcode must be on a separate line from packaged-on date and lot number values code format to enable scanning of GTIN by itself.

GTIN barcode format:

(01)GGGGGGGGGGGGGG, where:

- **P** = Package indicator; possible values include:
 - 01 = Application identifier denoting that next 14 digits are the unit GTIN number.
 - GGGGGGGGGGGGGG = 14 digit unit GTIN no.

Packaged on date format:

(13)YYMMDD, where:

- **13** = Application identifier denoting that next 6 digits (maximum no. of digits) are the packaged on date.
- **YYMMDD** = Packaged on date, e.g., 190704, indicates a packaged on date of July 4, 2019.

Lot number format:

(10)LLLLLLLLLLLLLLLLLLLL, where:

- **10** = Application identifier denoting the next string of characters is the lot number
- **LLLLLLLLLLLLLLLLLLLL** = Lot number value, can be letters or numbers, up to a 20 character maximum.

4.2.4 Packing Slip, Mixed SKU or Lot Notification

Packing slip – A master packing slip that contains a list of each SKU and case quantity must be included with each shipment. Each pallet must contain its own individual packing slip with a list of products contained on that pallet. Master BOLs or combined packing slips on pallets are not acceptable and will result in non-compliance penalties.

Mixed SKU or lot notification form – Pallets with multiple SKUs or lots must have an attached 8” x 10” bright yellow coloured paper indicating “Mixed SKU Pallet” or “Mixed Lot Pallet.” A Master Case cannot contain units from multiple lots and packaged on dates. The notification should be faced towards the trailer exit. Each case should have the same lot number for the units inside (matching the case label lot number), as traceability is required to be maintained. Cases identified to have units with more than one lot can lead to receiving delays.

4.2.5 Fragile SKUs

Edibles, extracts, topicals and vape products are not only subject to temperature sensitivity but may also be damaged during transport unless properly packed, stored and handled. Any SKUs noted as fragile are required to apply a fragile sticker to the side of the Master Case per SKU.



- One (1) 3” x 5” red fragile sticker on the side of the Master Case. Fragile tape will be allowed if a Master Case is too small to hold this sticker.
- Mixed Pallets – fragile and non-fragile items are allowed to be palletized together, keeping layers separate as per normal shipping requirements for mixed SKU pallets as specified in section 4.2.4.
- If a product is required to remain upright, LPs must include a “this side up” flag on the Master Case.

4.2.6 Temperature Monitoring

Edibles and other temperature-sensitive cannabis products are shelf-stable at room temperature, but not below 0°C or higher than room temperature. Temperature-sensitive products need to be stored and distributed in a temperature-controlled environment to maintain quality and food safety.

Transportation Temperature Monitoring Program - Participation in the Temperature Monitoring Program (TMP) is a requirement for LPs and AGLC’s warehouse for all inbound products that fall under temperature-sensitive products.

The roles of the TMP are as follows:

- LP is responsible for acquiring calibrated TempTale units and placing them within shipments.
- AGLC’s warehouse is responsible for reviewing and storing the TempTale data and reporting any non-conformance within the terms provided by AGLC.
- AGLC is responsible for determining temperature range and breach terms for all products to be accepted by AGLC’s warehouse, investigating reported non-conformance, and determining data retention.

Inbound TMP requirements

- Before a shipment is sent to AGLC’s warehouse, calibrated and pre-conditioned TempTale units must be placed within the shipment to ensure the temperature is accurately captured.
- The inside temperature of a trailer is recommended to be set at 18°C.
- Placement of the TempTale units must be on a yellow fluorescent paper affixed to the top of the pallet to ensure visibility.

Full truck load: In the back, mid and front of the trailer

Half load: In the back and front of the shipment

Three or fewer pallets: A single TempTale on a single pallet

Before the shipment is accepted, the shipped TempTale units will be collected by AGLC’s warehouse, and the data will be analyzed. Data will be extracted in pdf/Excel format.

In the event of receiving product outside of specific temperature ranges, AGLC’s warehouse will place product(s) on hold and contact AGLC QA. The product(s) will be inspected, and the decision to accept or reject the product(s) will be determined based on the inspection results.

AGLC QA will notify the LP in the event of a temperature breach and the results of the inspection. Required TempTale units that are missing at the shipment’s arrival are considered a range breach for that shipment.

Any range breach within the terms provided by AGLC will halt the shipment and receiving process. AGLC QA will investigate the breach and communicate its findings to the LP.

In the case of destruction being ordered by AGLC, the shipment will be handled within our facility in compliance with AGLC’s quarantine and destruction processes.

Note: range breaches are subject to refusal of the entire load and non-compliance fines.

Please contact our warehouse at CannabisReceiving@Connect-Logistics.com to set up return of TempTales (applicable to multi-use TempTales only).

Product Type	Acceptable Temperature Range (°C)	
	Min Temp	Max Temp
Distillate Liquid	5	22
Iced Tea	5	22
Sparkling Beverages	5	22
Sodas	5	22
Distillate Powder	5	22
Gum	5	22
Hard Candy	5	22
Kit	5	22
Oral Strips	5	22
Salty Snacks	5	22
Brownies	10	22
Soft Chews	10	22
Chocolates	10	22
Cookies	10	22
Cannabis Extracts*		
Cannabis Topicals*		
* Temperature range as defined by licensed producer		

4.3 Packing Products for Shipment to AGLC

Products must be packed in Master Cases that do not exceed the maximum size of 25.4cm (10") width x 30.48cm (12") length x 22.86cm (9") height. Minimum dimensions for a Master Case are 9.53cm (3.75") width x 12.7cm (5.0") length x 9.53cm (3.75") height.

Inner packaging is not permitted. A Master Case needs to contain retail unit packages only, and all retail units in a Master Case must be from the same lot. All cases must be shipped with the right side facing up and barcodes facing out.

Master Cases may be delivered on pallets that meet the following conditions:

- Pallets will be moved by machinery. Pallets must be sturdy enough for elevated storage in racking. Hardwood pallets like CHEP are acceptable.
- Pallets must be capable of being double stacked.
- Pallets must be 120cm x 100cm (48"x40"), two-way or four-way and have stringers (see illustration)
- Pallet must be in good condition and not damaged in any way.
- Pallets are considered one way and will not be returned.
- Whenever possible, partially loaded pallets should be avoided, and a single SKU should be loaded per pallet.
- When building the pallet, the number of Master Cases per layer must remain consistent.
- Maximum height of each pallet should not exceed 142.24cm (56"), including product (127cm or 50") and pallet (15.24cm or 6").
- Plastic pallets are not accepted.
- Pallets must be secured with cardboard corners placed vertically on the edges.

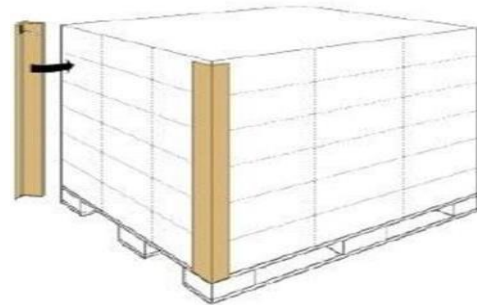
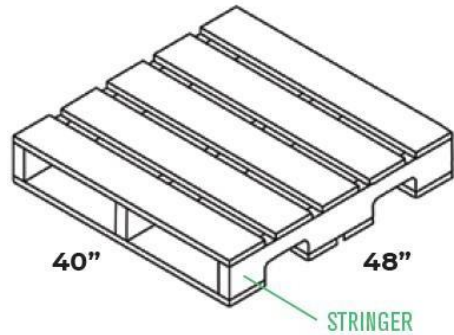

Shipments with **less than** 65 Master Cases on an ASN can be shipped via courier. For more information about using a courier option, please email CannabisReceiving@Connect-Logistics.com. All shipping criteria still applies to courier shipments.

4.4 Shipping to AGLC warehouse

4.4.1 The Shipping Process

The shipping process is defined by the steps below, starting with receiving a Purchase Order (PO) from AGLC and finishing once the product has been delivered to AGLC's warehouse via common carrier.

- 1. Submit Stock Status Report** – The LP must complete the **Stock Status Report** to indicate which products and quantities are available for purchase. The form must be completed in full and emailed to the designated Merchandising Planner.
- 2. Receive PO** – When AGLC is ready to place an order for product from the LP, AGLC will send the LP a PO. The PO will describe the products being purchased, the order quantity, the order date, an approximate delivery date, the PO close date and any other relevant details. POs must be delivered in full within 30 business days. AGLC will only place orders for registered products.
- 3. Prepare order** – After the PO is received, the LP should prepare the order to align with the requested delivery timeframe. Include TempTales for any product that requires temperature monitoring. LPs have 30 business days to fulfill and deliver an order to AGLC but are requested to attempt to meet the approximate requested delivery date, even if it is sooner than 30 business days. Orders may be fulfilled in multiple shipments.
- 4. Create Advance Shipping Notice (ASN)** Before shipping the order to AGLC, the LP must create an ASN. The ASN alerts AGLC's warehouse to the details of the inbound shipment. The ASN is created using the ASN Portal. See Section 4.4.2 Advance Shipping Notice for additional details.
- 5. Book a delivery appointment** – In order for AGLC to receive an order from an LP, a receiving time slot must be booked. To book a time slot, the LP (or in many cases the LPs carrier) must complete an Appointment Request Form (ARF). See Section 4.4.3 Appointment Booking for details about this form and the process of submitting it.
- 6. Confirmation of booked appointment** – After the ARF is submitted, the LP must wait for confirmation of their scheduled booking appointment before making the delivery. Typically, there are at least two business days between the appointment date and the appointment request.
- 7. Arrive at AGLC warehouse** – When the scheduled appointment date and time arrives, the carrier must deliver the goods within 15 minutes of their appointment. AGLC will accommodate late or early shipments with notice if they do not compromise other scheduled deliveries. Unauthorized late or early deliveries are subject to penalties. Late or early appointments will be reviewed by AGLC's warehouse to determine if the loads can be accepted. Early appointments may have to wait until the scheduled appointment time. Late appointments may be refused and re-booked to a different day.
- 8. Deliver the products** – AGLC will unload the products from the delivery vehicle at the warehouse. AGLC can inspect up to ten per cent of the cases of each SKU for accuracy. Should any discrepancies be found, a secondary inspection will be conducted on the remaining 90 per cent.

The LP will be responsible for inspection costs incurred during the secondary inspection.
The delivery driver will remain in the vehicle or waiting lounge until notified that the load has been received and verified.
- 9. Sign the BOL** – Once delivery has been made, a member of the warehouse team and the delivery driver must both sign the Bill of Lading to confirm delivery has been completed. Any apparent damage to the goods should be acknowledged by both the driver and the warehouse team and noted on the BOL before it's signed. The driver must stay at the warehouse facility until the shipment has been verified.

4.4.2 Advance Shipping Notice (ASN)

All product arriving at AGLC's warehouse must be on an open PO with AGLC.

An ASN is a required document containing information on products and quantities shipped to the warehouse in a single shipment. An ASN may be an entire PO or a portion of a PO if the PO will be filled in multiple shipments. A single ASN cannot be split over multiple deliveries, i.e., multiple containers/trailers. All ASNs must match the actual shipment in product, quantity, and lot. Products that arrive with a variance to the ASN or without a valid ASN will incur non-compliance penalties.

Providing correct information on the ASN is critical for the receiving process. Time slots are designated based on the characteristics of the ASNs associated with the load. For instance, a load with many SKUs in smaller quantities will be scheduled for a longer time. If the entire load is one SKU, generally, this type of load is processed more quickly, so a shorter period of time is scheduled.

If a load arrives with inaccurate ASN information, it may cause delays for other loads scheduled. Inaccurate ASNs will incur non-compliance penalties. The freight carrier must have a copy of the ASN that matches the one provided on the ASN Portal. Delays in off-loading will result in non-compliance fees and may result in the load being refused. An ASN or an ARF number is required to access the facility; a PO number is insufficient.

Allow two business days (unless otherwise approved by AGLC) for the ASN registration process to be completed prior to sending an Appointment Request Form (ARF). All ASNs must be booked via the online ASN Portal. ASNs cannot be revised after a delivery appointment has been confirmed.

The ASN Portal can be accessed at CannabisConnect.com. Each licensed producer will need a username(s) and password. To obtain access to the portal, send your LP name, username, phone number and email address to CannabisCS@connect-logistics.com. Usernames will be issued for licensed producers registered with the AGLC. Please include the main licensed producer and your affiliation if you are a subsidiary. Once registered, LPs will need to create ASNs based on the shipment being sent to AGLC's warehouse. The information provided in the portal must match the physical shipment to avoid delays and penalties.

When creating the ASN, the user will be asked to add the CoA for the shipped product. Once the ASN is issued, the user can complete an Appointment Request Form and send it to CannabisReceiving@connect-logistics.com to request a delivery appointment.

Questions regarding the ASN Portal can be sent to CannabisInventory@connect-logistics.com.

4.4.3 Appointment Booking

After creating the ASN, LPs (or their carrier) should send an Appointment Request Form (ARF) to book a delivery appointment. The ARF is provided to all LPs as part of their onboarding and can also be requested by emailing CannabisReceiving@connect-logistics.com or CannabisMerch@aglc.ca. All appointment bookings must be coordinated with AGLC's warehouse. Email the ARF to CannabisReceiving@connect-logistics.com.

Booking hours of operation are listed below:

- Monday – Friday - 7:30 a.m. to 3:30 p.m.
- Saturday and Sunday - Closed
- Stat Holidays - Closed

The LP (or carrier) must deliver the goods within 15 minutes of their scheduled appointment. AGLC will only accommodate late or early shipments if they do not compromise other scheduled deliveries. Late or early deliveries are subject to penalties or fees.

4.4.3 Other Shipping Rules

LPs must adhere to the additional shipping rules outlined in the table below, or they may be subject to penalties or additional charges.

ADDITIONAL SHIPPING REQUIREMENTS	
NO COMBINING Bill of Lading (BOL)	All ASNs must be contained by their own separate BOL. No combining of BOLs is allowed.
SHIPMENT DOCUMENTS	<p>The following documents must be included with the shipment: Bill of Lading Individual Packing Slip per pallet Mixed SKU or LOT notification (on pallets)</p> <p>Documents must contain correct information. Failure to submit all documents will result in receiving and clearance delays and/or additional charges. Additionally, the freight forwarder/carrier should have a copy of the ASN that matches the ASN Portal.</p>
TEMPERATURE CONTROL	<p>Temperature-sensitive products arriving outside the tolerance range will be subject to further inspection and possible shipment rejection. Additionally, if a load arrives damaged (e.g., frozen, melted, etc.), it will not be off-loaded pending authorization. Products shipped via common carrier are still required to ship using temperature controls.</p>
UNHYGIENIC SHIPMENTS	<p>Product must be shipped to prevent any cross-contamination or loss of quality. The trailer must be in good condition and free from harmful chemicals, vermin/insects, or unhygienic contaminants. Ensure shipments meet all entry requirements for wood packaging material into Canada under CFIA policy directive D-98-08. Inbound shipments must comply with GoodProduction Practices (GPP) requirements. Additionally, if a load arrives significantly damaged, it will not be off-loaded pending authorization (e.g., shifted, frozen, etc.).</p>
DELAY OF RECEIVING	<p>Any product that cannot be received, for example, product waiting for insurance inspection, will be held for a maximum of 10 business days and subject to storage fees. Product may also be held while QA processes are completed.</p>
PROOF OF DELIVERY	<p>AGLC will only sign for product after the load is verified and any exceptions noted.</p>

4.5 Non-Compliance Penalties

Any non-compliance with packaging and shipping requirements will result in a penalty of \$1,000 per occurrence and increase up to and including the cost to remedy the error, and/or rejection of the product.

Non-compliance includes, but not limited to, the following:

- **Non-compliant labelling** – Product must be labelled according to federal requirements and AGLC labelling requirements specified in **Section 4.2** Labelling Requirements.
- **No CoA** – Product received without Certificate of Analysis 48 hours before cannabis delivery to warehouse is subject to a fine and/or shipment rejection as per Inbound Product Compliance.
- **Out of specifications** – Product quality parameters are outside of registered Product Master specifications can result in shipment rejection.
- **Arrival time** – Shipments must arrive at pre-determined times. Late arrivals (greater than 15 minutes) may not be accepted.
- **No purchase order** – Product not on an open PO will not be accepted.
- **Incorrect ASN or no ASN** – Product, quantity or lot delivered does not match the ASN, or product not included on the ASN will not be accepted.
- **Shortages or overages** – Penalties will apply for product delivered short or in excess of the ASN. Product delivered in excess of the ASN may be refused.
- **Split ASN** – A single ASN may not be split across multiple shipments. Splitting an ASN may result in delays, penalties, or load refusal.
- **Unregistered product** – Product without a SKU registration will not be accepted.
- **No booking** – Product that arrives without a valid appointment will not be accepted.
- **Invalid shelf life** – Product that arrives with less than three-quarters of its remaining shelf-life may be refused.
- **Wrong Excise Stamps** – product with incorrect excise stamps will be refused.
- **No individual packing slips** – each pallet must contain a packing slip outlining the pallet's contents (SKU and case quantity).
- **Barcodes don't scan** – product will be put on hold or returned to LP. Value Added Services are available for relabeling. Additional charges will apply.
- **Product or Case Changes** - In case of any change to a product's packaging and labelling (including any changes to ingredients that may be changed on the label), the LP must inform AGLC QA before implementation.
- **Rebooking** - Appointments rescheduled with less than 48 hours' notice of the original appointment.
- **PO Close Date** – product not delivered in full by the PO Close Date will incur penalties of up to five per cent of the outstanding portion of the PO. LPs must notify the Merchandising Planner of any shortages or delays in advance of the PO Close Date to avoid penalties.

4.6 Value-Add Services

AGLC's third-party logistics provider (3PL) offers several Value-Add Services (VAS) that the LP may optionally use. VAS pricing is quoted and agreed upon between AGLC's 3PL and the LP. The table below summarizes some VAS offered.

Email cnbsvas@connect-logistics.com to inquire about VAS.

VALUE-ADD SERVICES	
Service	Service Details
Labelling	Master Case or product unit labelling or barcoding
Kitting/Secondary packaging/ On-packing	Any secondary packaging services, including Master Case size changes, Master Case reconfiguration, promotional packaging, Master Case inserts, etc.
Reporting	Custom reports requested by the LP to service AGLC
Product destruction	LP requested product destruction
First In First Out (FIFO) maintenance	Special requests to ship out of FIFO
Product inspections	Requested product inspections or required audits
Other services upon request	LPs may request other services to fit their business needs

4.7 Health Canada Consumer Information sheet

AGLC does not require LPs to include Health Canada's Information Sheet with their shipments. AGLC's warehouse has taken this responsibility on behalf of LPs by shipping its retailers on their initial order and upon request after that.

5. PRODUCT RETURNS & RECALLS

Expectations Regarding Cannabis Returns To The LP

5.1 Product Returns

As per AGLC's Supply Contract, AGLC may choose to return products to the LP at their discretion. Some reasons that AGLC may choose to initiate a return with an LP are as follows:

- The product arrives in an unhygienic state, stale-dated or otherwise unfit for sale.
- Products that are not labelled or packaged as per Health Canada guidelines. This includes incorrect or missing excise stamps or excise stamps not sticking to the product (for example, oil bottles).
- The product is not registered with AGLC.
- The product is subject to a recall.
- The product is out of the agreed Cannabis Product Master specifications.
- The product has aged or is projected to expire before it is sold.
- Faulty products are returned from retailers.

AGLC will make reasonable efforts to rectify any issue before initiating a return with an LP, but LPs are obliged to accept and refund any returns from AGLC. The LP will be responsible for any return-related costs, including shipping, administrative, inspection or packing costs. The LP will also be responsible for any MSRP reimbursement for recalled products returned at retail locations by customers.

AGLC may choose to destroy rather than return product to the LP if the product is unfit for repackaging or is the result of a retailer's return to AGLC.

A common carrier must be used to pick up all returns from the warehouse.

In the event of a customer complaint, AGLC will contact the LP. The LP must investigate the root cause of the complaint and provide a Corrective and Preventative Actions (CAPA) report within the given time frame.

5.2 Product Recalls

Any of the following organizations may initiate recalls:

- Health Canada
- AGLC
- The LP

Recalls are initiated for products that are unsafe for consumption, faulty or discovered to not follow federal or provincial laws, regulations, policies, or standards.

Recalls may also be initiated for safe products that align with federal and provincial laws, but do not meet the respective internal quality or consistency standards of the LP or AGLC.

The execution of the recall will be the responsibility of the LP. AGLC will aid in the recall by facilitating returns from retailers, posting notices, providing oversight, and otherwise providing reasonable assistance to preserve public health and safety and a high standard of product quality.

The LP must notify AGLC in writing as soon as Health Canada is informed of a voluntary recall. Recall announcements must be communicated immediately to AGLC's Quality Assurance (CannabisQualityAssurance-DL@aglc.ca), Senior Manager, Product and Stakeholder Engagement and Category Management Specialist (CategoryManagementSpecialist@aglc.ca), and Manager, Inventory Planning and Business Processes. In the event of a recall, the LP must ensure they adhere to federal and provincial recall guidelines and legislation. Additionally, LPs must follow any policies stipulated in the [Cannabis Representative Handbook](#) available on aglc.ca.

LPs are obligated to promptly comply with any product recalls issued by any applicable governmental authority.

The LP will be responsible for all reasonable costs associated with product recalls.

6. Payments

Financial Transactions With AGLC

6.1 Payment Set-up

To receive payments from AGLC, each LP must complete the Electronic Fund Transfer (EFT) Request Form and email it to vendormaintenance@aglc.ca. This form can be found [here](#).

Instructions are included on the form. Please ensure that you select the "Cannabis LP" box at the top of the form.

A completed EFT Request Form provides AGLC with the banking information required to deposit payments (via EFT) directly into the specified bank account.

6.2 Invoicing AGLC

Once the goods are accepted at AGLC's warehouse, related invoice(s) should be forwarded to ap@aglc.ca for processing and payment.

Each invoice must include the following:

- Quantity, purchase price and CNB number of goods shipped (referred to as 'the order').
- Deduction for the salvage/damage fee (as specified in the Supply Contract).
- The PO number that it is related to.

6.2.1 Sample Invoice

A sample invoice is provided for your reference.

ABC Company
 123 Street
 Edmonton, Alberta
 X0X 0X0
 Phone:

INVOICE

INVOICE #
 DATE:

TO:
 Attn: Accounts Payable
 AGLC
 50 Corriveau Avenue
 St. Albert, AB T8N 3T5
 780-447-8600

P.O. NUMBER	P.O. DATE	SHIP DATE	ASN #	BUYER	TERMS
MUST PROVIDE					2% 15 Days/Net 60

AGLC CNB #	SKU QUANTITY	ITEM NUMBER	DESCRIPTION	UNIT PRICE	TOTAL
MUST PROVIDE	9,000	Licensed Producer's Product Number	CNB Item Description	\$10.52	\$94,680.00
MUST PROVIDE	1,000	Licensed Producer's Product Number	CNB Item Description	\$15.50	\$15,500.00
				SUBTOTAL	\$110,180.00
				LESS: SALVAGE/DAMAGE FEE (2% SUBTOTAL)	-2,203.60
				TOTAL DUE (\$)	\$107,976.40

Please email each invoice to ap@aglc.ca

Payment for the invoice will be issued within 60 days of the invoice date. The invoice date is the date AGLC receives a correct invoice. The invoice date cannot be dated before AGLC has accepted the goods. If AGLC chooses to pay the invoice within 15 days of the invoice date, a two per cent discount will be applied to the total amount of the order at the time of the payment.

Payments at AGLC are processed weekly. A remittance notice (including a detailed list of invoices) for upcoming payments will be emailed on Wednesdays to the email address provided on the EFT Request Form. Payments are disbursed on Fridays. However, if required by AGLC, payments may be processed on an 'off-cycle' basis, i.e., any day during the week.

6.3 Credit Adjustments for Penalties or Fees

AGLC will issue invoices to an LP related to applicable fees and/or penalties if applicable. These credits are stipulated in the Supply Contract and include the following:

- Listing fees for registering SKUs with AGLC
- Fees/penalties for non-compliance

If AGLC issues a credit invoice, the LP will be provided with a copy of the invoice, emailed to the Finance contact provided to AGLC by the LP.

Unless specifically requested to do so by AGLC, please do not process payments to AGLC for these credit invoices. AGLC, at its sole discretion, may choose to request payment or deduct the balance from the following payment to the LP.

The total of any outstanding credits on account will be deducted against the payment posted into the LPs bank account, as discussed in Section 6.2 Invoicing AGLC, i.e., the amount paid will be the balance owed to the LP, net of any open AGLC credit invoices.

The summary of the credits will also be included in the remittance notice.

6.4 Taxes

As specified in the supply contract, the "purchase price" represents the landed cost to AGLC for goods and must include all applicable federal and provincial taxes.

As a Government of Alberta entity, AGLC is exempt from paying Goods and Services Tax (GST) or the Harmonized Sales Tax (HST) on taxable supplies and services purchases.

6.5 Payment Related Inquiries

If you have any questions regarding received/outstanding payments or payment-related processes, please forward your inquiries to ap@aglc.ca.

7. Contacts

How To Reach AGLC

The Alberta Cannabis Call Centre is AGLC's main communications channel for wholesale customers, as well as addressing questions and comments from Albertans.

ALBERTA CANNABIS CALL CENTRE

- Phone: 1 (855) 436-5677
- Hours: See our [website](#) for hours of operation
- Email: albertacannabis@aglc.ca

